

WBR

REINFORCED ANGLE BRACKETS

COMPLETE RANGE

Simple and effective angle brackets available in a full range of sizes to meet all structural and non-structural needs.

TIMBER AND CONCRETE

Due to the quantity and arrangement of the fastening holes, they can be used for both timber to timber, and timber to concrete connections.

DURABILITY

The 70, 90, and 100 mm models are also available in a stainless steel version made of A2 AISI 304.

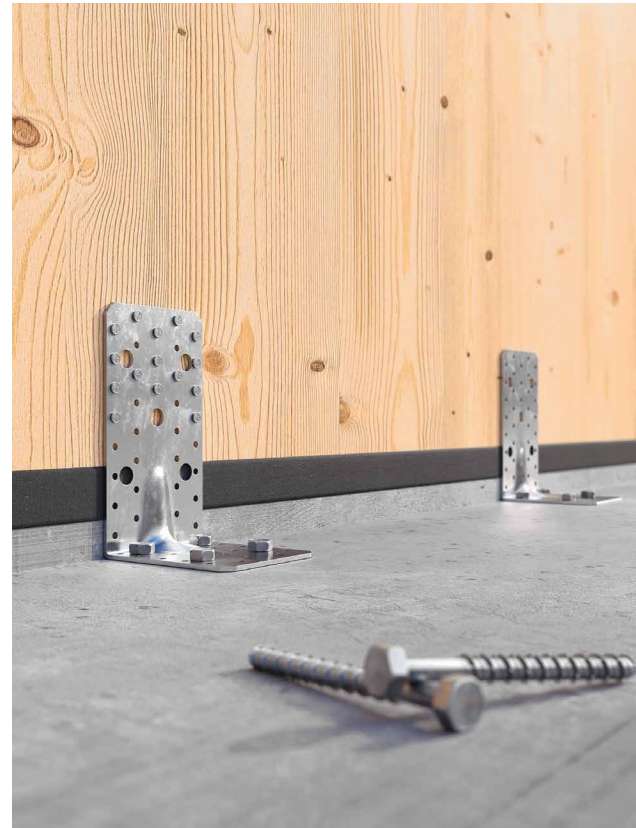

SERVICE CLASS

SC1 SC2 WBR

SC1 SC2 SC3 WBR A2

MATERIAL

DX51D
Z275 WBR: DX51D + Z275 carbon steel

A2
AISI 304 WBR A2: A2 stainless steel (AISI304)



FIELD OF USE

Structural or non-structural applications for fastening any timber element. Suitable for small structures and small carpentry connections.

Can be applied to:



- solid timber and glulam
- LVL
- other timber-based materials

CODES AND DIMENSIONS

WBR 70-90-100

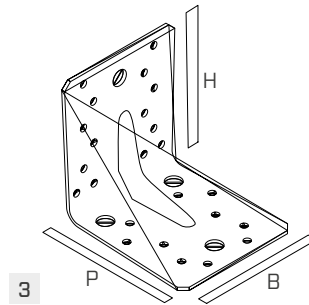
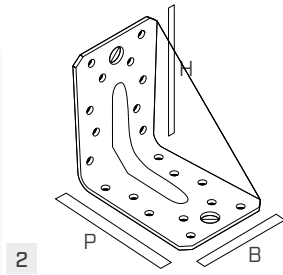
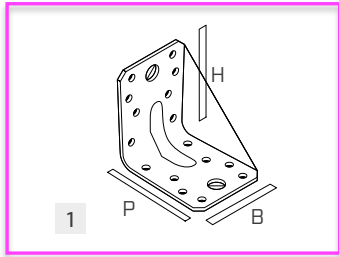
DX510
2275





CODE	B [mm]	P [mm]	H [mm]	s [mm]	n Ø5 [pcs]	n Ø11 [pcs]			pcs
1 WBR07015	55	70	70	1,5	16	2	●	●	100
2 WBR09015	65	90	90	1,5	20	2	●	●	100
3 WBR10020	90	105	105	2,0	24	4	●	●	50

WBR A2 70-90-100

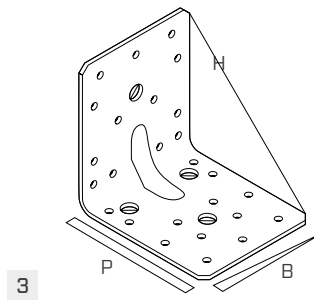
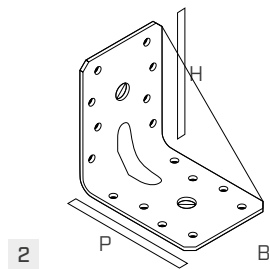
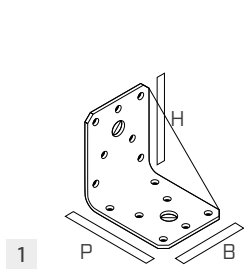
A2
AISI 304





CODE	B [mm]	P [mm]	H [mm]	s [mm]	n Ø5 [pcs]	n Ø11 [pcs]			pcs
1 AI7055	55	70	70	2,0	14	2	●	●	100
2 AI9065	65	90	90	2,5	16	2	●	●	100
3 AI10090	90	105	105	2,5	26	4	●	●	50

Not holding CE marking.



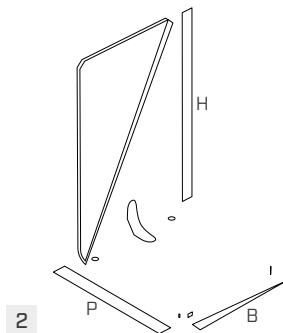
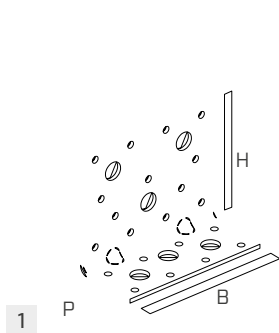



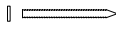

WBR 90110-170

DX510
2275

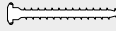

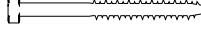
CODE	B [mm]	P [mm]	H [mm]	s [mm]	n Ø5 [pcs]	n Ø13 [pcs]			pcs
1 WBR90110	110	50	90	3,0	21	6	●	●	50
2 WBR170	95	114	174	3,0	53	9	●	●	25

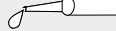
ADDITIONAL PRODUCTS - FASTENING

type	description		d [mm]	support
LBA	high bond nail		4	
LBS	round head screw		5	
SKR	screw-in anchor		10-12	
VIN-FIX	vinyl ester chemical anchor		M10 - M12	

FASTENING PATTERNS

TIMBER-TO-TIMBER

WBR07015

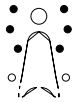

pattern 1



WBR09015

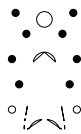

pattern 1

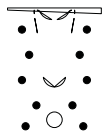

WBR10020

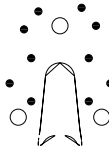

pattern 1

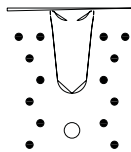

WBR90110

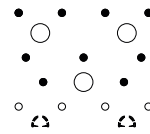

pattern 1



WBR170

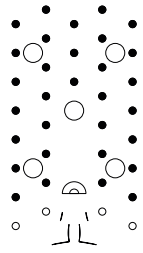

pattern 1

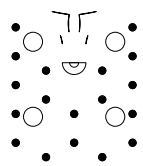

TIMBER-TO-CONCRETE

WBR07015

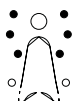

pattern 2

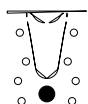

WBR09015

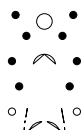

pattern 2

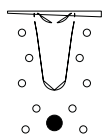

WBR10020

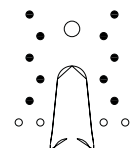

pattern 2

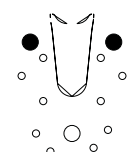

WBR90110

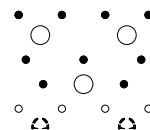

pattern 2



WBR170

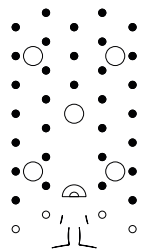

pattern 2

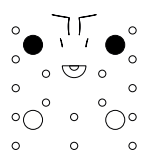

STRUCTURAL VALUES | TIMBER-TO-TIMBER | F_1

WBR07015 | WBR09015 | WBR10020 | WBR90110 | WBR170

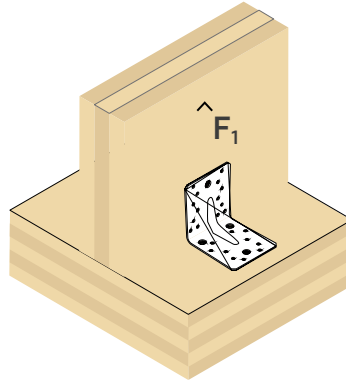

TIMBERSTRENGTH

CODE	configuration on timber	type	fastening holes Ø5			$R_{1,k}$ timber [kN]	$R_{1,k}$ steel [kN]
			Ø x L [mm]	n_V [pcs]	n_H [pcs]		
WBR07015	pattern 1	LBA	Ø4 x 60	6	8	2,0	-
		LBS	Ø5 x 60				5,0
WBR09015	pattern 1	LBA	Ø4 x 60	8	10	2,1	-
		LBS	Ø5 x 60				5,4
WBR10020	pattern 1	LBA	Ø4 x 60	10	14	4,1	-
		LBS	Ø5 x 60				11,0
WBR90110	pattern 1	LBA	Ø4 x 60	9	8	2,5	3,4
WBR170	pattern 1	LBA	Ø4 x 60	31	18	1,7	3,7

STRUCTURAL VALUES | TIMBER-TO-TIMBER | $F_{2/3}$

WBR07015 | WBR09015 | WBR10020 | WBR90110 | WBR170

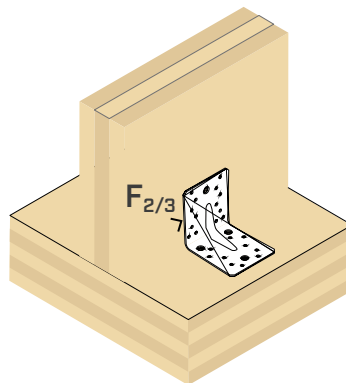

TIMBERSTRENGTH

CODE	configuration on timber	type	fastening holes Ø5			$R_{2/3,k}$ timber [kN]
			Ø x L [mm]	n_V [pcs]	n_H [pcs]	
WBR07015	pattern 1	LBA	Ø4 x 60	6	8	5,6
		LBS	Ø5 x 60			5,9
WBR09015	pattern 1	LBA	Ø4 x 60	8	10	6,8
		LBS	Ø5 x 60			7,1
WBR10020	pattern 1	LBA	Ø4 x 60	10	14	9,3
		LBS	Ø5 x 60			10,1
WBR90110	pattern 1	LBA	Ø4 x 60	9	8	7,1
WBR170	pattern 1	LBA	Ø4 x 60	31	18	11,0

GENERAL PRINCIPLES

For the GENERAL PRINCIPLES of calculation, see page 9.

STRUCTURAL VALUES | TIMBER-TO-TIMBER | F_4 | $F_{4/5}$

WBR07015 | WBR09015 | WBR10020

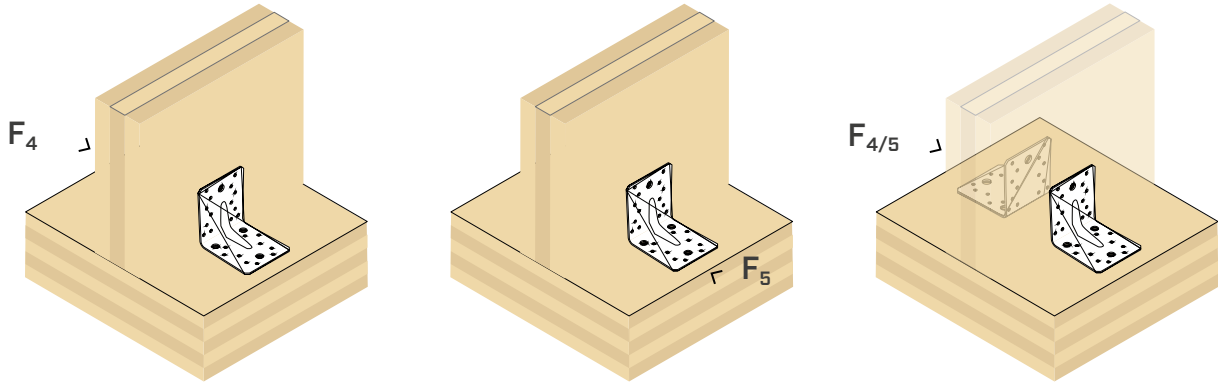

TIMBERSTRENGTH

CODE	configuration on timber	type	fastening holes Ø5			$R_{4,k}$ timber [kN]	$R_{5,k}$ steel [kN]	$R_{4/5,k}$ timber ^(*) [kN]
			Ø x L [mm]	n_V [pcs]	n_H [pcs]			
WBR07015	pattern 1	LBA	Ø4 x 60	6	8	6,3	1,1	7,4
		LBS	Ø5 x 60					
WBR09015	pattern 1	LBA	Ø4 x 60	8	10	6,6	1,2	7,7
		LBS	Ø5 x 60					
WBR10020	pattern 1	LBA	Ø4 x 60	10	14	11,1	2,2	13,3
		LBS	Ø5 x 60					

^(*) 2 angle brackets per joint.

STRUCTURAL VALUES | TIMBER-TO-TIMBER | $F_{4/5}$

WBR90110 | WBR170

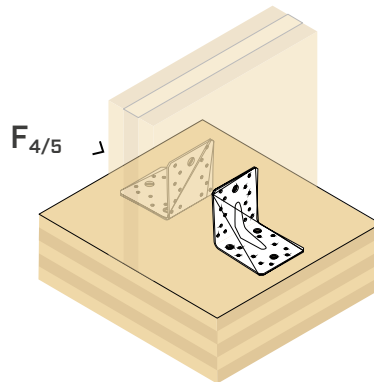

TIMBERSTRENGTH

CODE	configuration on timber	type	fastening holes Ø5			$R_{4/5,k}$ ^(*)	
			Ø x L [mm]	n_V [pcs]	n_H [pcs]	$R_{4/5,k}$ timber [kN]	$R_{4/5,k}$ steel [kN]
WBR90110	pattern 1	LBA	Ø4 x 60	9	8	10,4	10,9
WBR170	pattern 1	LBA	Ø4 x 60	31	18	12,4	9,2

^(*) 2 angle brackets per joint.

NOTES

- The F_4 , F_5 , $F_{4/5}$ values in the table are valid for the acting stress calculation eccentricity $e=0$ (timber elements prevented from rotating).

STRUCTURAL VALUES | TIMBER-TO-CONCRETE | F₁

WBR10020

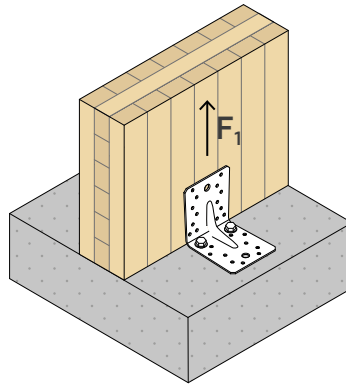

TIMBER STRENGTH

CODE	TIMBER			STEEL	
	type	fastening holes Ø5 Ø x L [mm]	n _V [pcs]	R _{1,k timber} [kN]	R _{1,k steel} [kN]
WBR10020	LBA	Ø4 x 60	10	26,6	8,6
	LBS	Ø5 x 60		24,1	8,6

CONCRETE STRENGTH

Strength values of some of the possible fastening solutions.

configuration on concrete	type	fastening holes Ø11 Ø x L [mm]	n _H [pcs]	R _{1,d concrete} [kN]	k _t //
uncracked	VIN-FIX 5.8	M10 x 140	2	21,2	1,15
	SKR	M10 x 80		11,7	
cracked	VIN-FIX 5.8	M10 x 140		11,8	
	SKR	M10 x 80		8,0	

CHEMICAL ANCHORS INSTALLATION PARAMETERS

anchor type		d ₀	h _{ef}	h _{nom}	h ₁	h _{min}
	Ø x L	[mm]	[mm]	[mm]	[mm]	[mm]
VIN-FIX 5.8	M10 x 140	12	115	115	120	200
SKR	M10 x 80	8	56	70	85	150

INA precut threaded rod complete with nut and washer: see INA data sheet at www.rothoblaas.com

GENERAL PRINCIPLES

For the GENERAL PRINCIPLES of calculation, see page 9.

STRUCTURAL VALUES | TIMBER-TO-CONCRETE | F_{2/3}

WBR10020

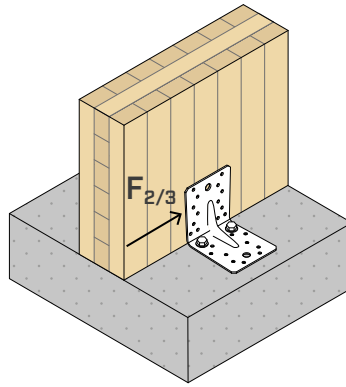

TIMBER STRENGTH

CODE	type	fastening holes Ø5		n _V [pcs]	R _{2/3,k} timber	
		Ø x L [mm]			[kN]	
WBR10020	LBA	Ø4 x 60		10		8,6
	LBS	Ø5 x 60				7,8

CONCRETE STRENGTH

Strength values of some of the possible fastening solutions.

configuration on concrete	type	fastening holes Ø11		R _{2/3,d} concrete [kN]	e _y [mm]
		Ø x L [mm]	n _H [pcs]		
uncracked	VIN-FIX 5.8	M10 x 140	2	27,1	21,5
	SKR	M10 x 80		16,1	
cracked	VIN-FIX 5.8	M10 x 140	2	27,1	21,5
	SKR	M10 x 80		11,2	

CHEMICAL ANCHORS INSTALLATION PARAMETERS

anchor type	Ø x L	d ₀ [mm]	h _{ef} [mm]	h _{nom} [mm]	h ₁ [mm]	h _{min} [mm]
VIN-FIX 5.8	M10 x 140	12	115	115	120	200
SKR	M10 x 80	8	56	70	85	150

INA precut threaded rod complete with nut and washer: see INA data sheet at www.rothoblaas.com

STRUCTURAL VALUES | TIMBER-TO-CONCRETE | F_{2/3}

WBR90110 | WBR170

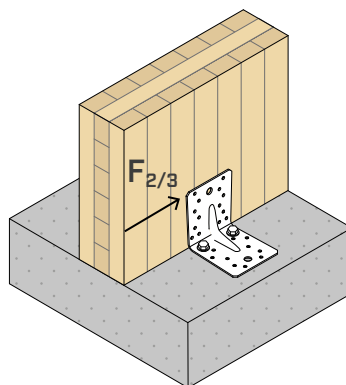

TIMBER STRENGTH

CODE	configuration on timber	fastening holes Ø5			fastening holes Ø11 n _H [pcs]	R _{2/3,k}	
		type	Ø x L [mm]	n _V [pcs]		R _{2/3,k} timber [kN]	Bolt _{2/3} ⁽¹⁾ [kN]
WBR90110	pattern 2	LBA	Ø4 x 60	9	2	7,1	0,71
WBR170	pattern 2	LBA	Ø4 x 60	31	2	11,0	0,65

⁽¹⁾Timber-to-concrete characteristic values are calculated by distributing part of the moment given by eccentricity on the nails. Other static diagrams can be calculated by the designer.

WBR07015 | WBR09015 | WBR10020

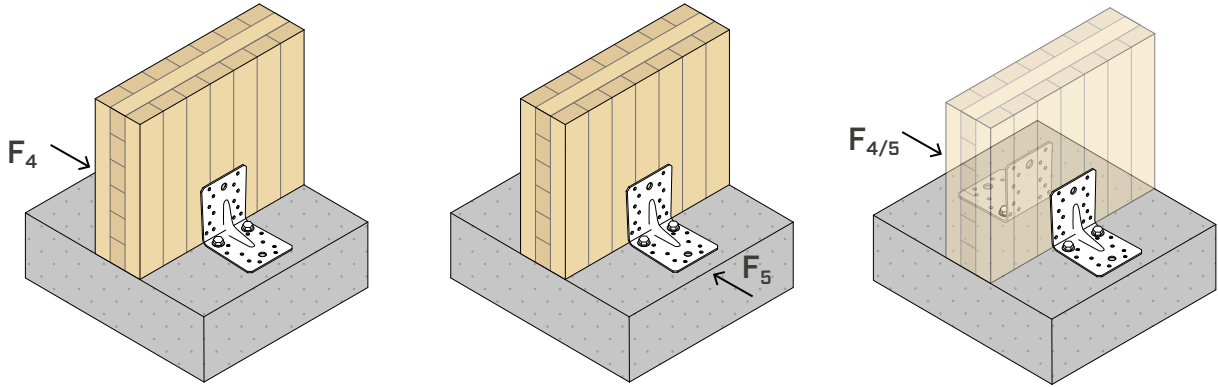

TIMBERSTRENGTH

CODE	configuration on timber	fastening holes Ø5			R _{4,k} timber [kN]	R _{5,k} steel [kN]	R _{4/5,k} timber ^(*) [kN]
		type	Ø x L [mm]	n _v [pcs]			
WBR07015	pattern 2	LBA	Ø4 x 60	6	6,3	1,1	7,4
		LBS	Ø5 x 60		6,3	1,1	7,4
WBR09015	pattern 2	LBA	Ø4 x 60	8	6,6	1,2	7,7
		LBS	Ø5 x 60		6,6	1,2	7,7
WBR10020	pattern 2	LBA	Ø4 x 60	10	11,1	2,2	13,3
		LBS	Ø5 x 60		11,1	2,2	13,3

The F₄, F₅, F_{4/5} values in the table are valid for the acting stress calculation eccentricity e=0 (timber elements prevented from rotating).

(*) 2 angle brackets per joint.

GENERAL PRINCIPLES

- Characteristic values are consistent with EN 1995-1-1 and in accordance with ETA. The design values of the anchors for concrete are calculated in accordance with the respective European Technical Assessments.
- The connection design strength values are obtained from the values on the table as follows:

$$R_d = \min \left\{ \begin{array}{l} \frac{R_{k,timber} \cdot k_{mod}}{\gamma_M} \\ \frac{R_{k,steel}}{\gamma_{steel}} \\ R_{d,concrete} \end{array} \right.$$

The coefficients k_{mod} and γ_M should be taken according to the current regulations used for the calculation.

- Installation with nails and screws of shorter length than proposed in the table is possible. In this case, the bearing capacity values R_{k,timber} must be multiplied by the following reductive factor k_F:

- for nails

$$k_F = \min \left\{ \frac{F_{v,short,Rk}}{2,83 \text{ kN}} ; \frac{F_{ax,short,Rk}}{1,39 \text{ kN}} \right\}$$

- for screws

$$k_F = \min \left\{ \frac{F_{v,short,Rk}}{2,41 \text{ kN}} ; \frac{F_{ax,short,Rk}}{3,28 \text{ kN}} \right\}$$

F_{v,short,Rk} = characteristic shear strength of the nail or screw

F_{ax,short,Rk} = characteristic withdrawal strength of the nail or screw

- Dimensioning and verification of timber and concrete elements must be carried out separately. Verify that there are no brittle failures before reaching the connection strength.
- Structural elements in timber, to which the connection devices are fastened, must be prevented from rotating.

- The calculation process used a timber characteristic density of ρ_k = 350 kg/m³ and a C25/30 concrete strength class with a thin reinforcing layer, where there is no spacing and edge-distance and minimum thickness indicated in the installation parameters tables of the anchors used. The strength values are valid for the calculation hypothesis defined in the table; for boundary conditions different from the ones in the table (e.g. minimum distances from the edge or different concrete thickness), the concrete-side anchors can be verified using MyProject calculation software according to the design requirements.

- The anchors seismic design was carried out in performance category C2, without ductility requirements on anchors (option a2) elastic design according to EN 1992-4, with α_{SUS} = 0,6. For chemical anchors it is assumed that the annular space between the anchor and the plate hole is filled (α_{gap} = 1).

- The product ETAs for the anchors used in the concrete-side strength calculation are indicated below:

- VIN-FIX chemical anchor according to ETA-20/0363;
- SKR screw-in anchor according to ETA-24/0024.